



330 ERV - ECM

IDEAL FOR WARM HUMID AREAS WITH HEAVY AIR CONDITIONER USE

- Contains 1 AHRI 1060 Certified 68-280 Enthalpy Core
- Reversible access, E-box can be located on either side.
- Microprocessor circuit board with built in interlock contacts.
- ERV will transfer water vapor from supply to exhaust reducing AC load.
- High efficiency electronically commutated motors (ECM).

DIMENSIONS

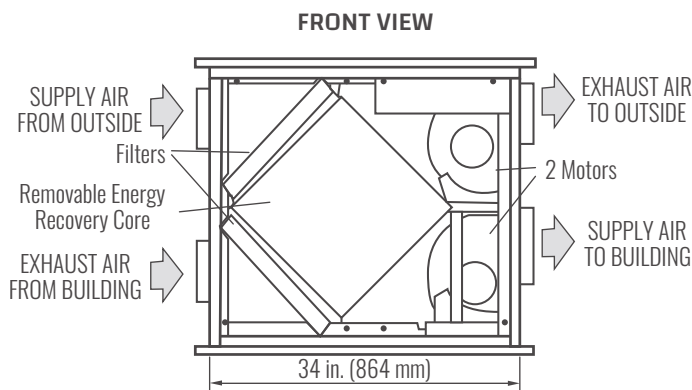

FEATURES

TOTAL RECOVERY CORE

The cross-flow energy recovery core transfers heat and water vapor between the two air streams. It is easily removed for cleaning or service.

MOTORS

Two ECM, 3 speed single shafted, 120 VAC, 3.8A each (7.6A total on maximum speed). 1/3 HP, 2000 RPM Max. MCA: 9.5A, MOP: 15A. Total on high speed: 210 watts @ 0.5 in H2O.

FILTERS

2 in. pleated MERV8 filters in supply and exhaust air streams. MERV 13 Upgrade: 65-237R.

BLOWERS

Slide easily in / out of unit. Centrifugal type rated at 460 CFM (217 L/s) free air delivery. Each air stream has one single shafted motor driving a centrifugal blower.

CONNECTION DUCT SIZES

Four 8 in. x 8 in. (200 mm x 200 mm).

MOUNTING

Unit to be set on support brackets hung by threaded rod type apparatus (brackets and rod not provided).

CABINET

Unit has front and back access doors and electrical panel. 22 gauge prepainted galvanized steel (G60) for superior corrosion resistance. Insulated with foil faced insulation where required to prevent exterior condensation.

ELECTRONICS

Integrated microprocessor circuit board. Built-in interlock contacts. Optional remote speed control.

FROST PREVENTION

Temperature sensor activated, periodically shuts down supply motor. Drains not required.

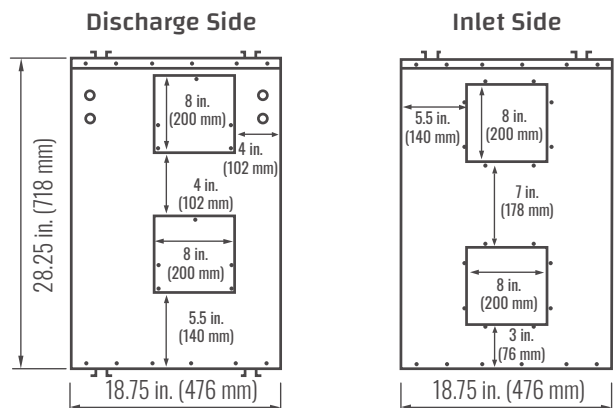

Weight: 120 lbs (54 KG) • Shipping Weight: 150 lbs (68 KG)

LIFEBREATH[®] 330ERV-ECM

Indoor Air Systems ENERGY RECOVERY VENTILATOR



AHRI 1060 Certified Core:
Contains one 68-280



ISO
9001
REGISTERED

NOTE:

The 330ERV-ECM model may easily be reversed in the field.
Service clearance is 30 in. (760 mm) from front access doors.

WARRANTY:

Units carry a 5 year warranty on the ERV core and a 2 year replacement parts warranty.

All units conform to CSA and UL standards

Airflows (Each Air Stream)

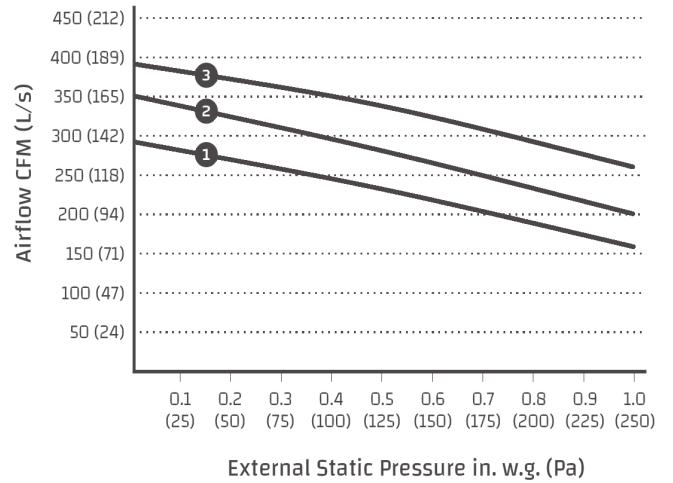

Total Effectiveness

